

KLM-40-0F2

Electric Linear Motor.

- ✓ Available in GREEN and GREEN**PLUS**
- ✓ Affordable electric technology to replace pneumatics
- ✓ Highest dynamic performance to dimension & weight ratio
- ✓ No need for fan or heat dissipator
- ✓ Programmable strokes, speed and motion parameter, fully programmable with field bus controller

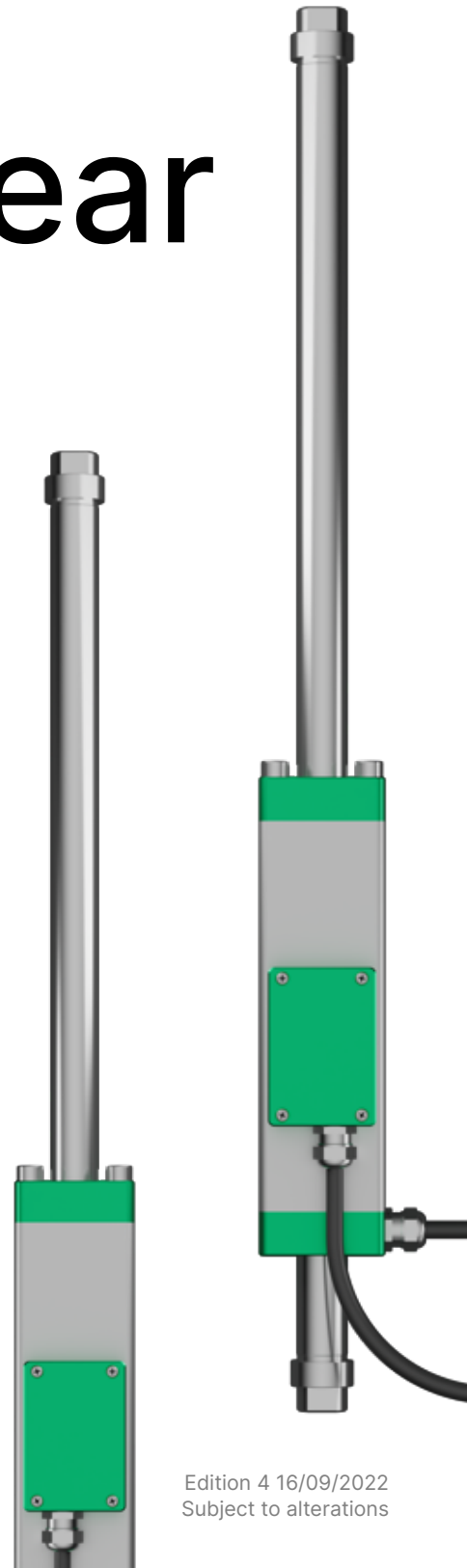

Linear Motor | KLM-40-0F2

Edition 4 16/09/2022
Subject to alterations



An innovative tubular three-phase low voltage (24/48 V) iron core technology to provide highest dynamic performance in the smallest footprint.

Each model is available in two variants:

- ▶ **GREEN** for the most cost sensitive applications requiring standard performance, this model is ideal for pneumatic replacements.
- ▶ **GREENPLUS** for higher output applications, to improve either quality of production or production rate.

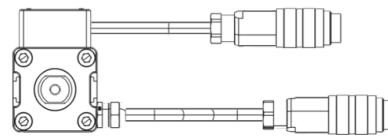

Front view

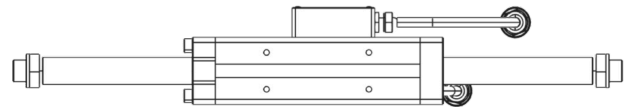

Side view

Technical Data

	GREEN	GREENPLUS
Continuous force, F_c [N] *	20	25
Peak Force, F_p [N]	32	40
Continuous current, I_c [A]		2
Peak current, I_p [A]		6
Force Constant [N/A]	5.4	6.8
Phase resistance, R_p [Ohm]	2.7	3.3
Repeatability [mm]		± 0.150
Accuracy [mm]	± 1	± 0.5
Max Acceleration, Acc_{max} [m/s ²]	185	225
Max. Average Speed, V_{max} [m/s]		2.1
Power supply, DC [V]		24 or 48
Operating temperature, T_{op} [°C]		-20...+45
Thermal Constant [K/W]	4.85	3.28
Slider mass, M_s [g]	200 + 1 gram X stroke (mm)	
Stator body mass, M_T [g]	825	
Overall Product Weight [g]	1025 + 1 gram X stroke (mm)	
Available strokes [mm]	40, 80, 120, 160, 200, 240	
Shaft bushing material	Sintered bronze	
Housing Material	Hard-anodized aluminium (aerospace grade)	
Shaft Material	Hard chrome plated stainless steel (AISI 316L)	
Sensor Technology	Hall Sensor Linear Encoder	

Drawing / Dimensions

*The maximum force the actuator can apply and stay below a temperature of 60°C.

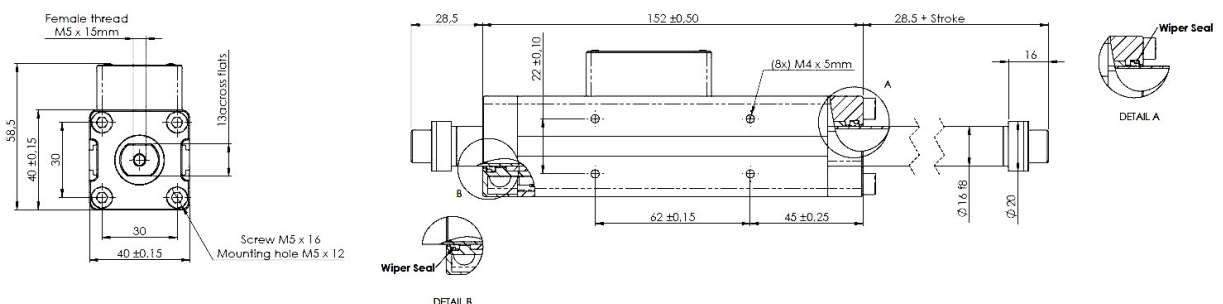

Stroke [mm]	GREEN	GREENPLUS
	Part Number	Part Number
40	KLM-40-0F2-GR-040	KLM-40-0F2-GRP-040
80	KLM-40-0F2-GR-080	KLM-40-0F2-GRP-080
120	KLM-40-0F2-GR-120	KLM-40-0F2-GRP-120
160	KLM-40-0F2-GR-160	KLM-40-0F2-GRP-160
200	KLM-40-0F2-GR-200	KLM-40-0F2-GRP-200
240	KLM-40-0F2-GR-240	KLM-40-0F2-GRP-240

Cable Type	Length [m]	Part Number
Power cable 3 × 0,50 mm ²	3	KLA-PWR-X-03-HF-A
	5	KLA-PWR-X-05-HF-A
	10	KLA-PWR-X-10-HF-A
Sensor cable 7 × 0.25 mm ²	3	KLA-SNR-X-03-HF-A
	5	KLA-SNR-X-05-HF-A
	10	KLA-SNR-X-10-HF-A

Notes:

- Both power and sensors cables are shielded cables made of PVC, Outer Diameter is 6 mm.
- On both extremities of each cable, there is one ferrite with 16 mm of outer diameter and 52 mm length.
- Operating temperature of both cables is in the range of -20° C to + 75° C.
- Cables are furnished with required connectors.
- Custom length of cables is available on request.

Accessories

Drivers (choose one from below)

- TCP/IP **KDRV-3-MK-TP** Electronic Driver with Ethernet
- KDRV-3-MK-PF** Electronic Driver with Profinet Module
- KDRV-3-MK-ET** Electronic Driver with EtherCat Module
- KDRV-1-MK** General Purpose Driver Digital I/Os
- KDRV-3-MK-PL** Electronic Driver with Power Link

Cable (choose from the "Ordering Data" section)

Setup

The motion setup is done through web server interface (GUI) embedded in the electronic controller which is needed to control the actuator.